

FIG. 1

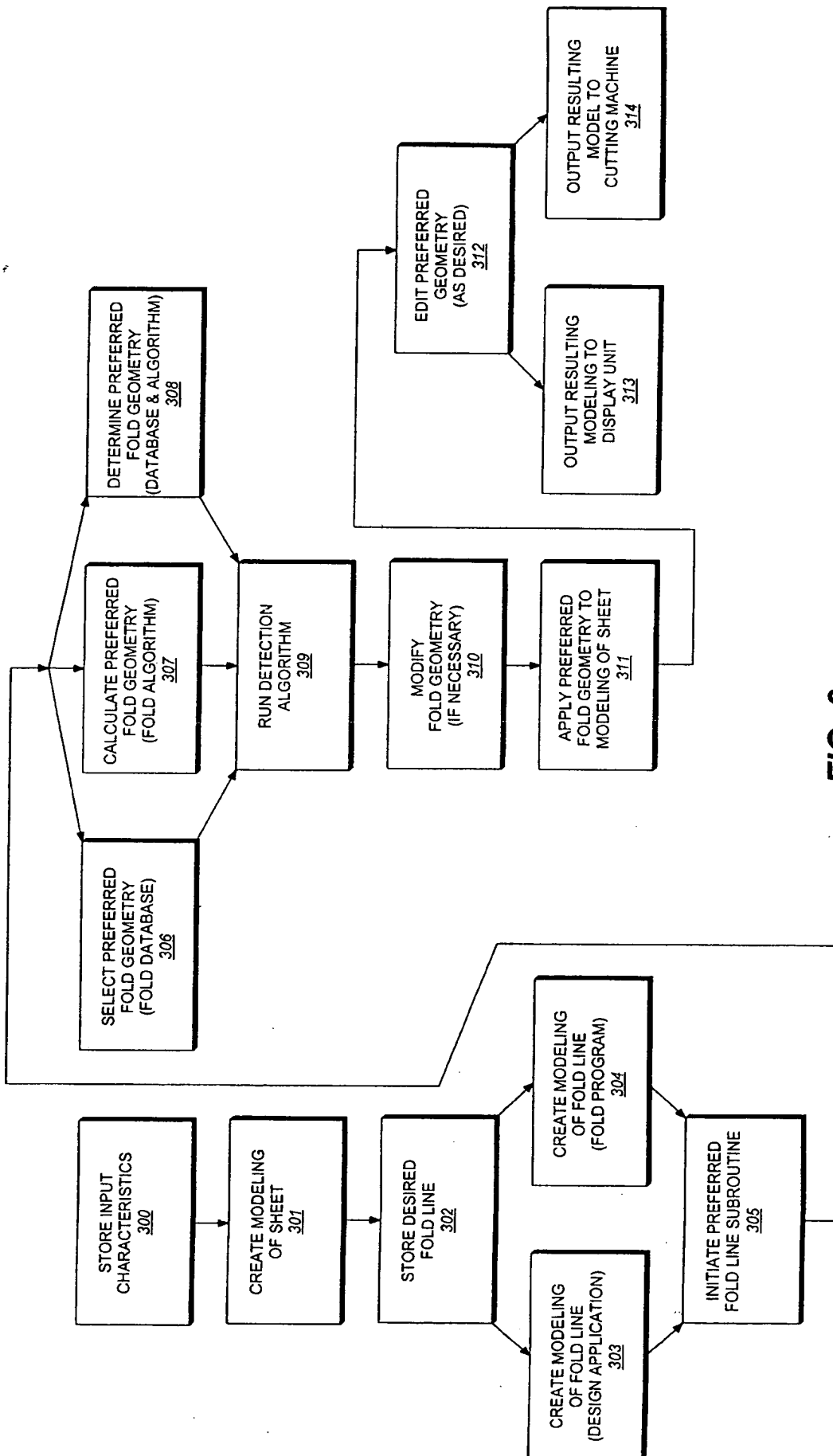
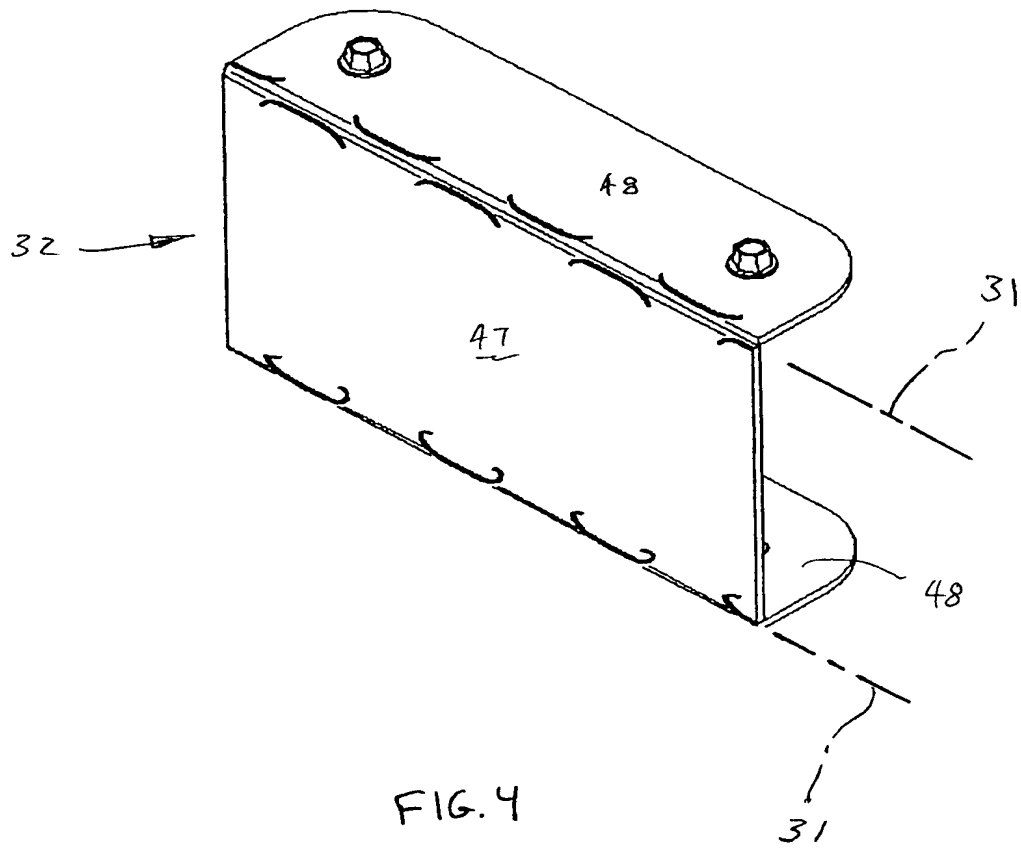

FIG. 2



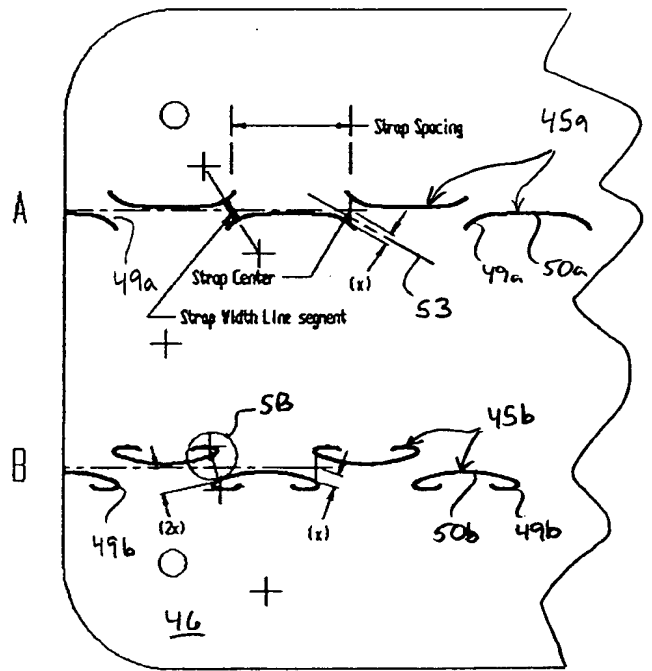
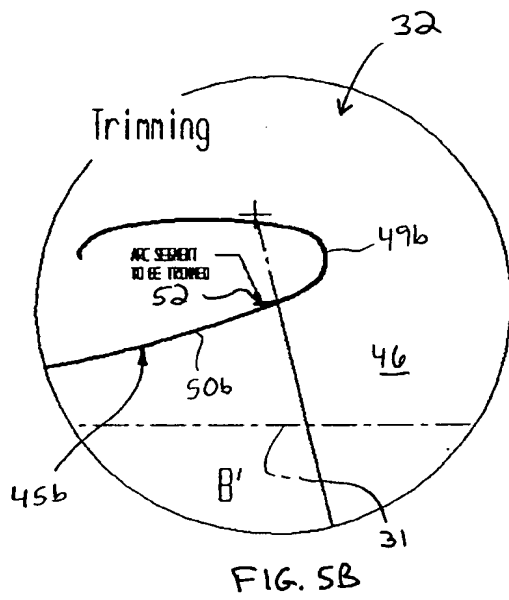

FIG. 5A

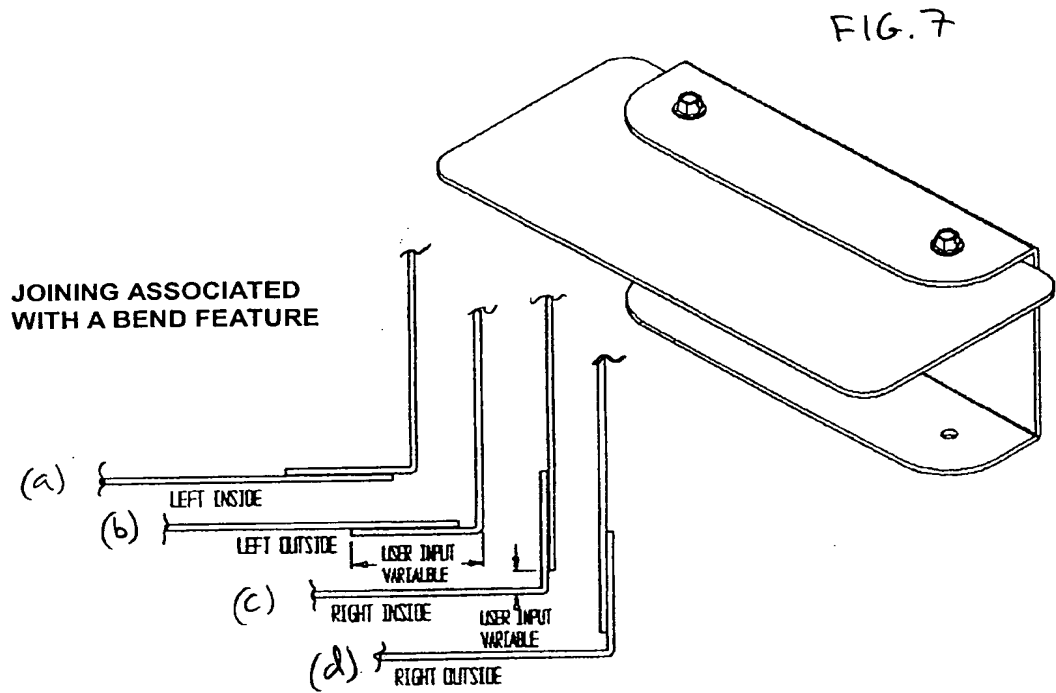

FIG. 6

BEND FEATURE

55

IOI ←	BRAKE ↓	JOINDER ^
USER INPUTS		
MATERIAL	STEEL A-36	
THICKNESS	0.104	
STRAP WIDTH	<input checked="" type="checkbox"/> WIDE	<input type="checkbox"/> M
STRAP SPACING	<input type="checkbox"/> CLOSE	<input checked="" type="checkbox"/> M
KERF	0.008	
FATIGUE STRENGTH	<input checked="" type="checkbox"/> LOW	<input type="checkbox"/> HIGH
MATERIAL VECTOR	0	0
CUTTER	ANGLE (DEG)	SCALER
	FOLD DEDUCTION	
	JOG	<input type="checkbox"/> ADVANCED
FLIP		

FIG. 8